

Novità/News/Neuheit/  
Nouveauté 2023

Designed by

Piero Lissoni, 2005-2023

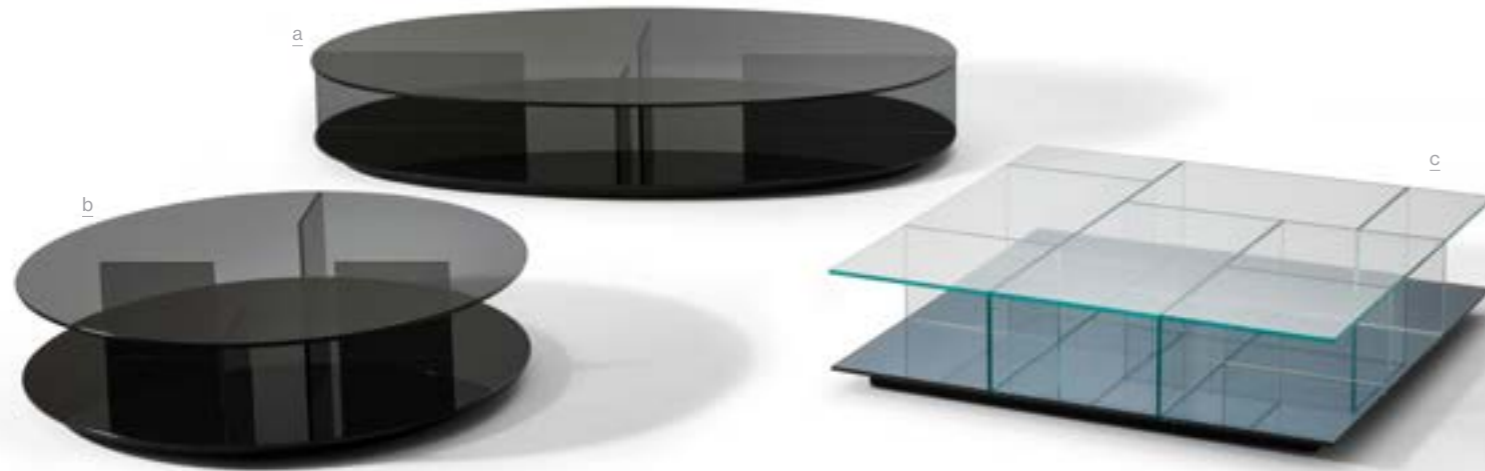

ITA

Una famiglia di tavolini ideali per la zona living, firmati da Piero Lissoni. Caratterizzati dalla forte identità stilistica, i modelli Mex uniscono linee semplici a profili definiti, accostando i raffinati piani in vetro alle basi, disponibili in una palette che spazia da toni chiari a sfumature più scure. L'eleganza immacolata del vetro avvolge questi modelli a cui è aggiunto un basamento di 4 cm in metallo verniciato nero opaco che li eleva da terra e consente di valorizzarli anche su tappeti più alti. In un gioco di incastri, ogni tavolino è reso ulteriormente funzionale dalle spalle a sostegno della superficie che creano scompartimenti in cui riporre riviste, libri e accessori. Disponibili in forme diverse - quadrata, circolare e ovale - e più dimensioni, i tavolini sono combinabili tra di loro per lasciare spazio alla creatività. Disponibile anche il piano in vetro fumé con la base retro-laccata nera, mentre il top in vetro extra-chiaro è combinabile a una base nelle finiture retro-laccato bianco o nero, vetro specchiante rosso mattone o caffè.

DEU

Eine Familie mit Beistelltischen des Designers Piero Lissoni, die perfekt für den Living-Bereich sind. Die Modelle Mex zeichnen sich durch ihre starke stilistische Identität aus und verbinden einfache Linien mit definierten Profilen durch die Kombination der exklusiven Tischplatten aus Glas mit den Tischfüßen in einer Farbpalette, die von helleren bis dunkleren Farbtönen reicht. Die reine Eleganz des Glases charakterisiert diese Modelle, die über ein zusätzliches 4 cm hohes Untergestell aus Metall mit Lackierung in Mattschwarz verfügen, das sie vom Boden abhebt und das Aufstellen der Beistelltische auch auf Teppichen mit hohem Flor erlaubt. Jeder Beistelltisch ist ein Spiel aus zusammengesetzten Teilen und besonders funktionell durch die Seitenteile, auf denen die Tischplatte aufliegt und die Fächer schaffen, die Platz für Zeitschriften, Bücher und andere Gegenstände bieten. Die Beistelltische sind in verschiedenen Formen (quadratisch, rund und oval) und mehreren Größen erhältlich und lassen sich kombinieren, um der Kreativität Raum zu geben. Mex ist auch mit Tischplatte aus Rauchglas und Tischfuß mit lackierter Rückseite in Schwarz erhältlich, und die Tischplatte aus extraweißem Glas kann mit einem Tischfuß mit lackierter Rückseite in Weiß oder Schwarz oder Spiegelglas in Ziegelrot oder Kaffeebraun kombiniert werden.

ENG

A family of low tables, ideal for the living room, designed by Piero Lissoni. Distinguished by their bold stylistic identity, the Mex models combine clean lines and distinct profiles, joining elegant glass tops to bases available in a colour palette that ranges from light hues to darker shades. The flawless elegance of glass envelops these models, to which a 4 cm metal base painted matte black has been added to elevate them off the floor, allowing them to be appreciated even on higher-pile rugs. In an interplay of joints, each table is made more functional by vertical support panels that create compartments for storing magazines, books and accessories. Available in different shapes - square, circular and oval - and several sizes, the low tables can be combined with one another to form creative arrangements. Also available with smoked glass top with base back-lacquered in black, while the extra-clear glass top can be combined with back-lacquered base in black or white, or with mirrored glass in brick red or coffee colour.

FRA

A family of low tables, ideal for the living room, designed by Piero Lissoni. Distinguished by their bold stylistic identity, the Mex models combine clean lines and distinct profiles, joining elegant glass tops to bases available in a colour palette that ranges from light hues to darker shades. The flawless elegance of glass envelops these models, to which a 4 cm metal base painted matte black has been added to elevate them off the floor, allowing them to be appreciated even on higher-pile rugs. In an interplay of joints, each table is made more functional by vertical support panels that create compartments for storing magazines, books and accessories. Available in different shapes - square, circular and oval - and several sizes, the low tables can be combined with one another to form creative arrangements. Also available with smoked glass top with base back-lacquered in black, while the extra-clear glass top can be combined with back-lacquered base in black or white, or with mirrored glass in brick red or coffee colour.

Base

- Metallo verniciato nero opaco con piedini in materiale plastico.
- Struttura
- Piano superiore in vetro extra-chiaro temperato con spalle in vetro extra-chiaro, e base in vetro extra-chiaro temperato retro-laccato bianco o nero, o in vetro specchiante rosso mattone o caffè.
- Piano superiore in vetro fumé temperato con spalle in vetro fumé, e base in vetro fumé temperato retro-laccato nero.

269 72 Q\_

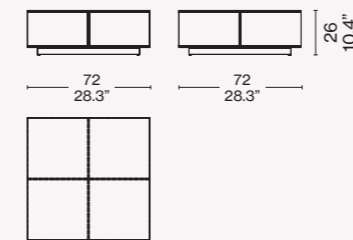

269 10 R\_

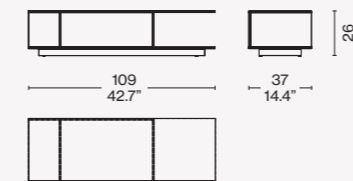

Base

- Matte black-painted metal, with feet in plastic material.
- Structure
- Table top in extra-clear tempered glass with supports in extra-clear glass, and base in extra-clear, tempered, black or white black-lacquered glass, or in mirrored glass, brick red or coffee coloured.
- Table top in smoked tempered glass with supports in smoked glass, and base in smoked tempered black back-lacquered glass.

269 10 Q\_

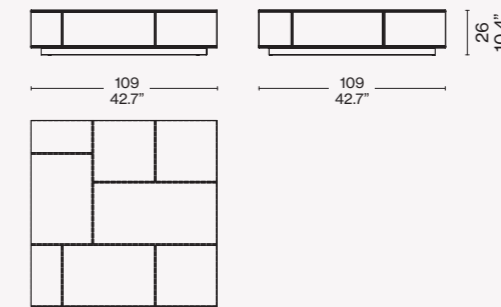

269 72 T\_

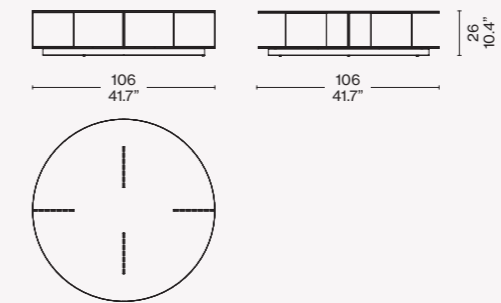

269 72 R\_

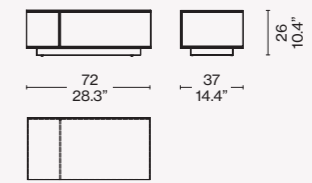

269 17 V\_

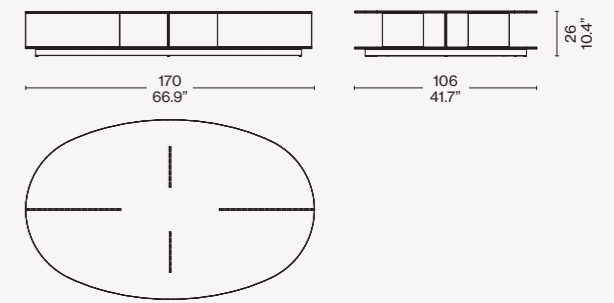

Finiture/Finishes/  
Ausführungen/Finitions



a/b

base vetro retrolaccato nero/black back-lacquered glass base/schwarz hinterlackierter Glasfuß/base en verre laqué noir  
top vetro temperato fumé/smoked tempered glass top/Basis aus geräuchertem Sicherheitsglas /base en verre trempé fumé



c

base vetro retrolaccato caffè/coffee back-lacquered glass base/Basis aus kaffee bemaltem Glas/base en verre laqué café  
top vetro temperato extra chiaro/extra-clear tempered glass top/Basis aus extra hellem Sicherheitsglas /base en verre trempé extra clair

